

ucylisoleucine, respectively. The increased stability ($\Delta \log \beta_{1-11}$) is also linearly correlated with the hydrophobicity scale.

The present paper confirms the importance of hydrophobic interactions between aliphatic as well as aromatic ligands in the complex formation and correlates successfully the enhanced stability of both binary and ternary copper(II) complexes with

the hydrophobicity of side chains of coordinated amino acids.

Acknowledgment. This investigation was supported by a Grant-in-Aid for Scientific Research (No. 62540444) and a Grant-in-Aid for Special Project Research (No. 62124039) from the Ministry of Education, Science and Culture (Japan).

Contribution from the Laboratory of Analytical Chemistry,
Faculty of Science, Nagoya University, Chikusa, Nagoya 464-01, Japan

Variable-Pressure Oxygen-17 NMR Studies on Acetic Acid Exchange of Manganese(II) Perchlorate and Manganese(II) Acetate¹

Masao Ishii, Shigenobu Funahashi,* and Motoharu Tanaka

Received March 8, 1988

Acetic acid exchange of manganese(II) perchlorate and manganese(II) acetate in acetic acid (HOAc) involving dichloromethane-*d*₂ as a diluent has been studied at various pressures up to 180 MPa by the variable-pressure ¹⁷O FT-NMR line-broadening method. The activation volumes at 258 K are $+0.4 \pm 0.7 \text{ cm}^3 \text{ mol}^{-1}$ for $\text{Mn}(\text{ClO}_4)_2$ and $+6.7 \pm 0.6 \text{ cm}^3 \text{ mol}^{-1}$ for $\text{Mn}(\text{OAc})_2$, respectively. These positive values are unusual for the solvent exchange on manganese(II) studied so far and are discussed in terms of the bulkiness of acetic acid molecules and the effect of the ligand bound to the manganese(II).

Introduction

The activation volume, ΔV^\ddagger , is now accepted as a criterion of the activation mode of a variety of inorganic reactions in solution such as the solvent exchange on metal cations and the formation of metal complexes.²⁻⁵ We have measured the activation volumes for the formation of some metal complexes by the high-pressure stopped-flow method, and the following results were obtained.⁶⁻⁹ The activation volume for the complex formation of iron(III) greatly depends on the bulkiness of both the solvent molecule and the ligand; the bulkier the solvent molecule or the ligand, the less associative the activation mode. These findings indicate that it is difficult for the bulky entering ligand to enter into the inner-coordination sphere of a metal cation and that the activation mode becomes less associative for bulkier solvents or bulkier entering ligands, which make the inner-coordination sphere of metal cation sterically more crowded in the activation state. This phenomenon would be significant for the reactions of metal ions such as high-spin *d*⁵ iron(III) that proceed via an associative activation mode in a nonbulky solvent such as water.^{6,7} On the other hand, the activation volumes for the complexation of the *d*⁸ nickel(II) ion are positive even in a nonbulky solvent such as water, acetonitrile, or methanol and are not as sensitive to the bulkiness of solvent and ligand molecules as in the case of iron(III); the complex formation of nickel(II) always proceeds via a dissociative interchange (I_d) mechanism.⁸

Recently, the exchange of *N,N*-dimethylformamide (DMF) on high-spin *d*⁵ manganese(II) was studied^{10,11} and a small but positive value was observed, though the solvent exchange on this cation

is known to proceed via an associative interchange mechanism in nonbulky solvents such as water,¹² methanol,¹³ and acetonitrile.¹⁴ We have already reported the kinetic parameters, except for the activation volume, for the acetic acid exchange of manganese(II) perchlorate¹⁵ and manganese(II) acetate.¹⁶ We have measured the activation volumes for these reactions at 258 K by the variable-pressure ¹⁷O FT-NMR line-broadening method. On the basis of the activation volumes, we will discuss the effect of the bulkiness of acetic acid and the bound ligand effect on the activation mode of the solvent exchange of manganese(II).

Experimental Section

Variable-Pressure NMR Measurements. For variable-pressure ¹⁷O NMR experiments, a high-pressure NMR probe fitted with the electromagnet (2.34 T) of a JEOL JNM-FX100 FT-NMR spectrometer operating at 13.50 MHz was constructed. The probe consists of two separable parts: an aluminum support with a tuning network, shim coils, etc. and a pressure vessel. The pressure vessel consisting of three separable parts is illustrated in Figure 1A. The pressure cylinder (1) made of nonmagnetic titanium alloy is covered with a copper cylinder inside of which a spiral is cut. The thermostating nitrogen gas is circulated along the spiral in order to adjust the temperature in the pressure vessel. An adapter (2) made of titanium alloy is attached to facilitate insertion and withdrawal of the sample tube. The pressure cylinder is connected to an electrical terminal (3) into which the leading wires for the radio-frequency coil and copper-constantan thermocouple are introduced with small cones soldered separately to seal the pressure. The pressure sealing in other parts is achieved with a cone-type seal and O-ring seals.

The sample tube, illustrated in Figure 1B, is filled with the sample solution. The flexible Teflon cap (j) and the piston (k) transmit the hydrostatic pressure to the sample solution. The piston and the contractive Teflon tube (l) completely protect the sample solution in the glass tube (m) from contamination by the surrounding pressure-transmitting liquid.

The pressure vessel is connected through the flexible tube (SUS316; 1.702-mm o.d., 0.305-mm i.d.) to a pressure-generating system consisting

- (1) Metal Complexes in Acetic Acid. 10. For part 9, see ref 16.
- (2) Merbach, A. E. *Pure Appl. Chem.* **1982**, *54*, 1479-93.
- (3) Swaddle, T. W. *Adv. Inorg. Bioinorg. Mech.* **1983**, *2*, 95-138.
- (4) Merbach, A. E. *Pure Appl. Chem.* **1987**, *59*, 161-72.
- (5) *Inorganic High Pressure Chemistry: Kinetics and Mechanisms*; Van Eldik, R., Ed.; Elsevier: Amsterdam, 1986.
- (6) Ishihara, K.; Funahashi, S.; Tanaka, M. *Inorg. Chem.* **1983**, *22*, 194-8.
- (7) Ishihara, K.; Funahashi, S.; Tanaka, M. *Inorg. Chem.* **1983**, *22*, 2070-3.
- (8) Ishihara, K.; Funahashi, S.; Tanaka, M. *Inorg. Chem.* **1983**, *22*, 2564-7.
- (9) Ishihara, K.; Funahashi, S.; Tanaka, M. *Inorg. Chem.* **1983**, *22*, 3589-92.
- (10) Ishii, M.; Funahashi, S.; Tanaka, M. *Chem. Lett.* **1987**, 871-4.
- (11) (a) Cossy, C.; Helm, L.; Merbach, A. E. *Helv. Chim. Acta* **1987**, *70*, 1516-25. (b) Fielding, L.; Moore, P. J. *Chem. Soc., Chem. Commun.* **1988**, 49-52.

- (12) Ducommun, Y.; Newman, K. E.; Merbach, A. E. *Inorg. Chem.* **1980**, *19*, 3696-703.
- (13) Meyer, F. K.; Newman, K. E.; Merbach, A. E. *J. Am. Chem. Soc.* **1979**, *101*, 5588-92.
- (14) Sisley, M. J.; Yano, Y.; Swaddle, T. W. *Inorg. Chem.* **1982**, *21*, 1141-5.
- (15) (a) Hioki, A.; Funahashi, S.; Ishii, M.; Tanaka, M. *Inorg. Chem.* **1986**, *25*, 1360-4. (b) Hioki, A.; Funahashi, S.; Tanaka, M. *Inorg. Chem.* **1983**, *22*, 749-52.
- (16) Hioki, A.; Funahashi, S.; Tanaka, M. *Inorg. Chem.* **1986**, *25*, 2904-7.

Table I. Compositions of Sample Solutions

sample soln		$[\text{Mn}]/m^a$	$[\text{HOAc}]/m$	$[\text{CD}_2\text{Cl}_2]/m$	$[\text{HClO}_4]/m$	P_M	wt % of HOAc	atom % of ^{17}O
A0		0	3.31	9.20	2.12×10^{-2}	0	20.0	5.98
A	$\text{Mn}(\text{ClO}_4)_2$	6.02×10^{-4}	3.31	9.20	2.12×10^{-2}	5.46×10^{-4}	20.0	5.98
B0		0	3.37	9.16	0	0	20.4	5.13
B	$\text{Mn}(\text{OAc})_2$	2.30×10^{-4}	3.37	9.16	0	2.06×10^{-4}	20.4	5.13

^a $m = \text{mol kg}^{-1}$.

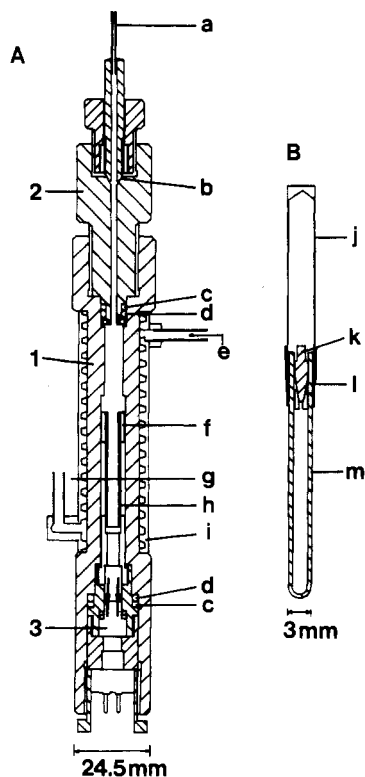

Figure 1. Pressure vessel and sample tube for high-pressure NMR measurements. (A) Pressure vessel: 1, pressure cylinder (titanium alloy); 2, adaptor (titanium alloy); 3, electrical terminal; a, flexible tube (SUS316); b, cone-type seal; c, backup ring (Teflon); d, O-ring (Viton); e, thermostating nitrogen gas; f, sleeve (Teflon); g, rf-coil center; h, bobbin (glass); i, copper cylinder. (B) Sample tube: j, flexible Teflon cap; k, piston (Teflon); l, contractive Teflon tube; m, glass tube.

of a high-pressure-generating pump (KP5-B, Hikari Kouatsu Co.), Heise Bourdon gauges, and a separator shown in Figure 2. The separator is useful to separate the pressure-transmitting liquid in the pressure vessel from the liquid in the high-pressure-generating pump because the former liquid must be chosen according to the nucleus observed. In this work, we used DAIFLOIL No. 3 (poly(chlorotrifluoroethylene), Daikin Co.), which does not contain oxygen in the pressure vessel and ShinEtsu Silicone KF96 350 cs (Shin-Etsu Chemical Co.) in the pressure-generating pump.

For ^{17}O NMR measurements, a 90° pulse width of $70 \mu\text{s}$ and pulse intervals of $0.05\text{--}0.075 \text{ s}$ were used. By use of the external lock unit, the free induction decay signals were accumulated over 7200–24 000 times. The half-height width of the ^{17}O NMR spectra obtained by the high-pressure probe was broader by 6 Hz than that obtained by the tunable probe used normally under the same conditions. The ^{17}O NMR spectra were measured at various pressures at $258.0 \pm 0.3 \text{ K}$.

Sample Preparation. The compositions of sample solutions (solutions A and B) studied are listed in Table I. Oxygen-17-enriched acetic acid was prepared by mixing purified acetic anhydride with an equivalent amount of oxygen-17-enriched water purchased from CEA. Sample solutions were diluted with inert dichloromethane- d_2 in order to lower the freezing point of the solution. The perchloric acid concentration of the manganese(II) perchlorate solution (solution A) was made $2.12 \times 10^{-2} m$ in order to prevent solvolysis of manganese(II). Procedures of the sample preparation were described previously.^{15a,16} The amount of water in the present system is at most less than $1 \times 10^{-3} \text{ mol kg}^{-1}$. Transfer of the sample solution into a high-pressure NMR sample tube was carried out under a dry nitrogen atmosphere. Under the present experimental conditions, $\text{Mn}(\text{ClO}_4)_2$ exists as a hexakis(solvent)manganese(II) ion that

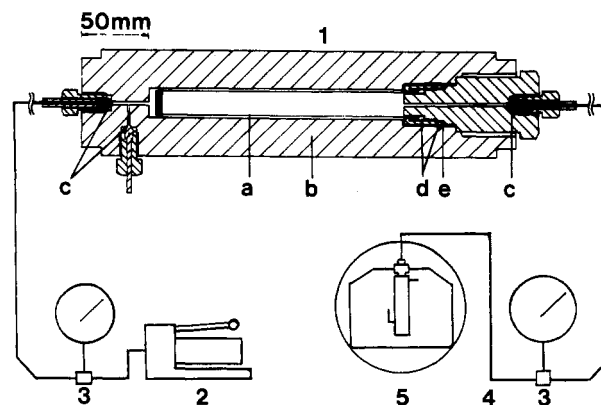

Figure 2. Pressure-transmitting liquid separator and schematic diagram of a pressure-generating system: 1, pressure-transmitting liquid separator; 2, high-pressure-generating pump; 3, Heise Bourdon gauge; 4, flexible tube; 5, NMR magnet and probe; a, flexible Teflon cap; b, cylinder (SUS360); c, cone-type seal; d, O-ring (Viton); e, backup ring (Teflon).

forms a nondissociated ion pair of $\text{Mn}(\text{HOAc})_6(\text{ClO}_4)_2$ with the perchlorate anion¹⁵ and $\text{Mn}(\text{OAc})_2$ exists as bis(acetato)tetrakis(solvent)manganese(II) in acetic acid.¹⁶

Treatment of NMR Line-Broadening Data. The exchange rate of a solvent between the bulk and the coordination site of a paramagnetic metal ion was estimated from the transverse relaxation rate of the bulk solvent nuclei.^{17–19} The solvent ^{17}O NMR line broadening, $(T_{2P}P_M)^{-1}$, due to a paramagnetic metal ion is expressed as

$$(T_{2P}P_M)^{-1} = \pi(\Delta\nu_{\text{obsd}} - \Delta\nu_{\text{solv}})P_M^{-1} \quad (1)$$

where $\Delta\nu_{\text{obsd}}$ and $\Delta\nu_{\text{solv}}$ are in this case the half-height widths of the ^{17}O NMR spectra of acetic acid in the bulk in the presence and in the absence of the manganese(II) ion, respectively. P_M is given as $P_M = fP_M'$, where f is now a factor of $1/2$ (vide infra) and P_M' is the ratio of the number of acetic acid molecules bound to manganese(II) to that of acetic acid molecules in the bulk. One of two oxygen atoms in a coordinated acetic acid molecule is directly bonded to the manganese(II), and the other oxygen atom does not coordinate. The contribution of the latter to the line width should be negligible. On the other hand, the two oxygen atoms of an acetic acid molecule in the bulk are equivalent. Thus f is accepted to be $1/2$. In the case of $P_M \ll 1$, $(T_{2P}P_M)^{-1}$ is given by the modified Swift-Connick equation^{17–19}

$$\frac{1}{T_{2P}P_M} = \frac{1}{\tau_M} \frac{T_{2M}^{-2} + (\tau_M T_{2M})^{-1} + (\Delta\omega_M)^2}{(\tau_M^{-1} + T_{2M}^{-1})^2 + (\Delta\omega_M)^2} + \frac{1}{T_{2O}} \quad (2)$$

in which symbols have their usual meaning.²⁰ The temperature dependences of $(T_{2P}P_M)^{-1}$ and kinetic parameters for both systems have been reported previously.^{15a,16} At 258 K where $T_{2M}^{-2} \gg \tau_M^{-2}$, $T_{2M}^{-2} \gg (\Delta\omega_M)^2$, and $\tau_M^{-1} \gg T_{2O}^{-1}$ are valid for both systems, eq 2 is reduced to

$$(T_{2P}P_M)^{-1} = \tau_M^{-1} \quad (3)$$

where τ_M is the mean lifetime of the ^{17}O nucleus of the acetic acid molecule in the inner sphere of manganese(II). Thus τ_M^{-1} is equivalent to the rate constant for solvent exchange k_{ex} . The acetate in $\text{Mn}(\text{OAc})_2(\text{HOAc})_4$ seems to form an intramolecular hydrogen bond with one of coordinated acetic acid molecules, and the interconversion between structural isomers such as cis and trans is very fast. Therefore we assume that all six ligands on the manganese(II) ion are exchanging equivalently although two are OAc^- and four are HOAc .

(17) Swift, T. J.; Connick, R. E. *J. Chem. Phys.* **1962**, *37*, 307–20.

(18) Luz, Z.; Meiboom, S. *J. Chem. Phys.* **1964**, *40*, 1058–66.

(19) Rusnak, L. L.; Jordan, R. B. *Inorg. Chem.* **1976**, *15*, 709–13.

(20) Hioki, A.; Funahashi, S.; Tanaka, M. *J. Phys. Chem.* **1985**, *89*, 5057–61.

Table II. Kinetic Parameters for the Solvent Exchange of Manganese(II)

	$k_{\text{ex}}(25\text{ }^\circ\text{C})/\text{s}^{-1}$	$\Delta H^\ddagger/\text{kJ mol}^{-1}$	$\Delta S^\ddagger/\text{J mol}^{-1}\text{ K}^{-1}$	$\Delta V^\ddagger/\text{cm}^3\text{ mol}^{-1}\text{ (T/K)}$	ref
$\text{Mn}(\text{HOAc})_6^{2+}$	1.6×10^7	29 ± 2^a	-10 ± 7^a	$+0.4 \pm 0.7$ (258)	c
$\text{Mn}(\text{OAc})_2(\text{HOAc})_4$	4.8×10^7	32 ± 3^b	9 ± 11^b	$+6.7 \pm 0.6$ (258)	c
$\text{Mn}(\text{DMF})_6^{2+}$	2.7×10^6	35.8 ± 0.6	-2 ± 2	$+1.6 \pm 0.5$ (309.5)	10
$\text{Mn}(\text{H}_2\text{O})_6^{2+}$	2.1×10^7	32.9 ± 1.3	5.7 ± 5.0	-5.4 ± 0.1 (298)	12
$\text{Mn}(\text{CH}_3\text{OH})_6^{2+}$	3.7×10^5	25.9	-50.2	-5.0 ± 0.2 (279)	13, 22
$\text{Mn}(\text{CH}_3\text{CN})_6^{2+}$	1.4×10^7	29.6 ± 0.5	-8.9 ± 2.0	-7.0 ± 0.4 (252–260)	14

^a Reference 15a. ^b Reference 16. ^c This work.

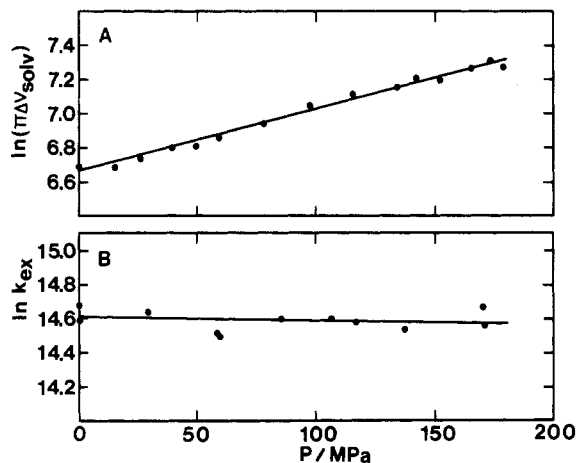

Figure 3. Pressure dependence of the manganese(II) perchlorate system: (A) pressure dependence of $\ln [\pi(\Delta\nu_{\text{solv}})]$ for soln A0 at 258 K; (B) pressure dependence of $\ln k_{\text{ex}}$ for acetic acid exchange of manganese(II) perchlorate at 258 K.

Water Exchange of Nickel(II) Perchlorate. In order to check the reliability of the newly built high-pressure NMR probe, we first measured the activation volume for water exchange of nickel(II) perchlorate in aqueous solution, for which the value has already been reported to be $+7.1 \pm 0.2\text{ cm}^3\text{ mol}^{-1}$.²¹ The temperature dependence of $\Delta\nu_{\text{obsd}}$ and $\Delta\nu_{\text{solv}}$ was measured over the range 293.7–339.8 K. Activation parameters for water exchange of the nickel(II) ion were obtained as follows: k_{ex} (298 K) = $(3.8 \pm 0.1) \times 10^4\text{ s}^{-1}$, $\Delta H^\ddagger = 49.2 \pm 2.5\text{ kJ mol}^{-1}$, and $\Delta S^\ddagger = 8 \pm 8\text{ J mol}^{-1}\text{ K}^{-1}$. The pressure dependence of $\pi(\Delta\nu_{\text{solv}})$ and k_{ex} at 311 K is shown in Figure S1 in the supplementary material. The volume of activation was determined to be $+7.2 \pm 0.2\text{ cm}^3\text{ mol}^{-1}$, which is in excellent agreement with the reported value.²¹

Results

Acetic Acid Exchange of Manganese(II) Perchlorate. The pressure dependence of $\Delta\nu_{\text{obsd}}$ and $\Delta\nu_{\text{solv}}$ was measured at 258 K. The pressure dependences of $\pi(\Delta\nu_{\text{solv}})$ and k_{ex} are shown in Figure 3. $\ln [\pi(\Delta\nu_{\text{solv}})]$ increases linearly with increasing pressure. The usual method of linear least squares for the plot in Figure 3A yielded

$$\ln [\pi(\Delta\nu_{\text{solv}})] = 6.66 + 3.7 \times 10^{-3}P/\text{MPa} \quad (4)$$

The k_{ex} value at any pressure was calculated from the difference between the observed value of $\Delta\nu_{\text{obsd}}$ and the $\Delta\nu_{\text{solv}}$ value evaluated from eq 4. According to the transition-state theory, the pressure dependence of the rate constant is given by $(\partial \ln k_{\text{ex}(P)}/\partial P)_T = -\Delta V^\ddagger/RT$. Since the plot is linear within the experimental errors as apparent from Figure 3B, ΔV^\ddagger is independent of pressure. Therefore, the pressure dependence of $(T_{2p}P_M)^{-1}$ was analyzed by a least-squares fitting to

$$\ln [(T_{2p}P_M)^{-1}] = \ln k_{\text{ex}(P)} = \ln k_{\text{ex}(0)} - (\Delta V^\ddagger/RT)P \quad (5)$$

where $k_{\text{ex}(P)}$ and $k_{\text{ex}(0)}$ are the rate constants at pressures P and zero, respectively. The obtained activation volume is $+0.4 \pm 0.7\text{ cm}^3\text{ mol}^{-1}$.

Acetic Acid Exchange of Manganese(II) Acetate. The pressure dependence of $\pi(\Delta\nu_{\text{solv}})$ and k_{ex} are shown in Figure 4. From Figure 4A we have $\ln [\pi(\Delta\nu_{\text{solv}})] = 6.42 + 4.7 \times 10^{-3}P/\text{MPa}$. The

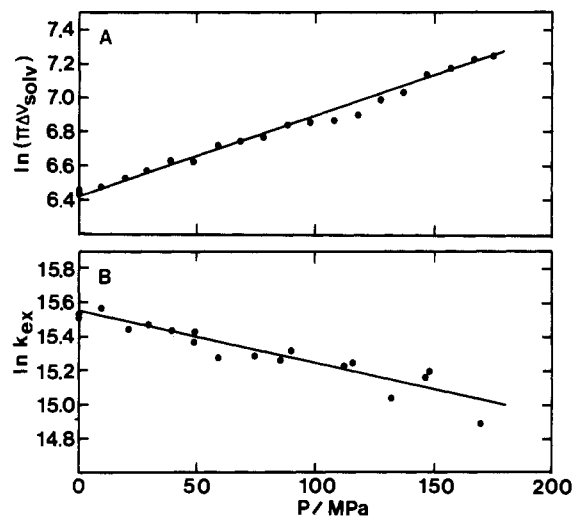

Figure 4. Pressure dependence of the manganese(II) acetate system: (A) pressure dependence of $\ln [\pi(\Delta\nu_{\text{solv}})]$ for soln B0 at 258 K; (B) pressure dependence of $\ln k_{\text{ex}}$ for acetic acid exchange of manganese(II) acetate at 258 K.

volume of activation was determined to be $\Delta V^\ddagger = +6.7 \pm 0.6\text{ cm}^3\text{ mol}^{-1}$ at 258 K.

Kinetic parameters for the solvent exchange of manganese(II) are summarized in Table II together with the results obtained so far.

Discussion

The volume of activation ΔV^\ddagger is generally considered to be the combination of an intrinsic contribution and a solvation contribution.²³ $\Delta V^\ddagger = \Delta V^\ddagger_{\text{intr}} + \Delta V^\ddagger_{\text{solv}}$, in which $\Delta V^\ddagger_{\text{intr}}$ is the intrinsic volume change caused by bond making or bond breaking and $\Delta V^\ddagger_{\text{solv}}$ is the volume change with variation of solvation. Since the acetic acid molecule is neutral, the change of electrostatic interaction during the activation process is expected to be very small and $\Delta V^\ddagger_{\text{solv}} \approx 0\text{ cm}^3\text{ mol}^{-1}$.^{4,5} Thus, in this case ΔV^\ddagger reflects the intrinsic volume change. The activation volume for $\text{Mn}(\text{ClO}_4)_2$ nearly equal to zero ($\Delta V^\ddagger = +0.4 \pm 0.7\text{ cm}^3\text{ mol}^{-1}$) is indicative of the interchange (I) mechanism. On the other hand, the activation volume of $+6.7 \pm 0.6\text{ cm}^3\text{ mol}^{-1}$ for $\text{Mn}(\text{OAc})_2$ is positive but quite smaller than the molar volume ($57.2\text{ cm}^3\text{ mol}^{-1}$ at 293 K) of acetic acid. Therefore, the mechanism for the solvent exchange of $\text{Mn}(\text{OAc})_2$ is dissociative interchange (Id).

It has been shown that the activation mode for the solvent exchange in water, methanol, and acetonitrile changes from associative (Ia) for Mn^{2+} to dissociative (Id) for Ni^{2+} with the increase in atomic number.²⁴ Such a changeover has been already explained in terms of the electronic configuration in the valence shell. The mechanism of the solvent exchange of the manganese(II) ion has been claimed to be associative interchange (Ia) on the basis of available negative volumes of activation in those solvents (see Table II). However, the positive volume of activation for the solvent exchange of manganese(II) in DMF has been reported recently.^{10,11}

Increase of the activation volume in acetic acid and DMF is thought to be due to the bulkiness of the solvent molecule. The

(21) Ducommun, Y.; Earl, W. L.; Merbach, A. E. *Inorg. Chem.* **1979**, *18*, 2754–8.

(22) Breivogel, F. W., Jr. *J. Chem. Phys.* **1969**, *51*, 445–8.

(23) Swaddle, T. W. *Coord. Chem. Rev.* **1974**, *14*, 217–68.

surroundings of manganese(II) coordinated by six bulky solvent molecules such as acetic acid or DMF should be sterically crowded. Therefore, the distance between manganese(II) and two donor atoms of the two equivalent bulky entering and leaving solvent molecules participating in the activation state would have to be longer than in nonbulky solvents such as water, methanol, and acetonitrile. The effect of the bulkiness of solvent and/or ligand on the activation volume observed in the complexation of iron(III) as mentioned in the Introduction is still valid for the solvent exchange of manganese(II).

Manganese(II) acetate is the solvolyzed species of manganese(II) perchlorate in acetic acid. As apparent from Table II, the activation volume for acetic acid exchange of manganese(II) acetate is definitely larger and the exchange rate of manganese(II) acetate is about 3 times faster than that of manganese(II) perchlorate. The enhanced rate of the solvent exchange or the ligand substitution on solvolyzed species has been observed also in other systems. Some complex formations in water are faster for the hydroxopentaquaairon(III) ion than for the hexaaquaairon(III) ion.^{6,7} The activation volume is negative for $\text{Fe}(\text{H}_2\text{O})_6^{3+}$, while it is positive for $\text{Fe}(\text{H}_2\text{O})_5(\text{OH})^{2+}$.^{6,7} Moreover, the kinetics of water exchange have been investigated for trivalent metal ions such as Ga^{3+} , Fe^{3+} , Cr^{3+} , and Ru^{3+} and for their monohydroxo species.^{4,24,25} Water-exchange rates for monohydroxo species are some orders of magnitude faster than for hexaaqua species. The activation volumes for monohydroxo species are larger than those

for corresponding hexaaqua species.

It is considered that the coordinated solvent molecules are labilized by the electron donation from the bound ligands such as CH_3COO^- and OH^- to the metal ion in solvolyzed species and that the activation mode of the reaction is less associative. The labilization by the bound ligand has been discussed quantitatively on the basis of the electron-donating ability of the bound ligand and the softness parameter of the metal ion.²⁶ The measurement of activation volume led us to the general mechanistic aspect of labilization of solvent molecules by the bound ligand; i.e., the stretch of the bond between the metal ion and the leaving solvent molecule in the activation process becomes longer by the electron donation from the bound ligand and the electron donation will electrostatically disfavor the approach of the donor atom of an entering solvent molecule, and thus the electron donation will inhibit associative character.

Acknowledgment. This work was supported by a Grant-in-Aid for Scientific Research (No. 62470041) and a Grant-in-Aid for Special Project Research (No. 62124039) from the Ministry of Education, Science, and Culture. We thank Prof. J. Jonas (University of Illinois) for his advice on the construction of our high-pressure NMR probe.

Registry No. $\text{Mn}(\text{ClO}_4)_2$, 13770-16-6; $\text{Mn}(\text{OAc})_2$, 638-38-0; HOAc , 64-19-7.

Supplementary Material Available: Pressure dependence of $\pi(\Delta\nu_{\text{solv}})$ and k_{ex} for water exchange of the nickel(II) ion (Figure S1) (1 page). Ordering information is given on any current masthead page.

(24) Swaddle, T. W.; Merbach, A. E. *Inorg. Chem.* **1981**, *20*, 4212-6.

(25) Xu, F.-C.; Krouse, H. R.; Swaddle, T. W. *Inorg. Chem.* **1985**, *24*, 267-70.

(26) Tanaka, M.; Yamada, S. *J. Chem. Soc., Chem. Commun.* **1976**, 178-9.

Contribution from the Department of Chemistry,
The University of North Carolina, Chapel Hill, North Carolina 27514

Influence of Variations in the Chromophoric Ligand on the Properties of Metal-to-Ligand Charge-Transfer Excited States

Susan R. Johnson, T. David Westmoreland, Jonathan V. Caspar,^{1a} Khaled R. Barqawi,^{1b} and Thomas J. Meyer*

Received September 3, 1987

The effects of variations in the chromophoric ligand on the properties of the metal-to-ligand charge-transfer (MLCT) excited states in the series $[\text{Os}(\text{PP})_3]^{2+}$, $[(\text{PP})_2\text{Os}(\text{py})_2]^{2+}$, and $[(\text{PP})_2\text{Os}(\text{LL})]^{2+}$ (PP = 2,2'-bipyridine, 1,10-phenanthroline, or a substituted derivative; py = pyridine; LL = das, dpmm, dppb, dppene) have been investigated. From a series of electrochemical and photophysical measurements it has been determined that (1) substituent variations in the chromophoric ligands have a relatively minor effect on the $d\pi(\text{Os})$ levels as evidenced by variations in $E_{1/2}$ values for the ground-state Os(III/II) couples, (2) linear correlations exist between metal-to-ligand charge-transfer (MLCT) absorption or emission band energies and the difference in metal-based oxidation and ligand-based reduction potentials, $E_{1/2}(\text{Os}^{\text{III/II}}) - E_{1/2}(\text{PP}^{0/-})$, and (3) a linear relationship between $\ln k_{\text{nr}}$ and the emission energy, E_{em} , exists, consistent with the "energy gap law". It appears that for nonradiative decay both the pattern of acceptor vibrations and the vibrationally induced electronic coupling term remain relatively constant as the chromophoric ligand is varied.

Introduction

Several recent studies based on polypyridyl complexes of Os(II) and Ru(II) have been aimed at developing a detailed understanding of the factors at the microscopic level that determine the properties of metal-to-ligand charge-transfer (MLCT) excited states. These studies, which have been summarized in a recent review,² have addressed, for example, the effects on photophysical properties of variations in nonchromophoric ligands,³⁻⁷ in the

solvent,⁸ in the counterion,⁹ and in the chromophoric ligands.^{10,11} The results have led to a detailed picture of how excited-state

(1) (a) Present address: Central Research and Development Department, Experimental Station, E. I. du Pont de Nemours and Co., Wilmington, DE 19898. (b) On sabbatical leave from Yarmouk University, Irbid, Jordan.

(2) Meyer, T. J. *Pure Appl. Chem.* **1986**, *58*, 1193.

(3) (a) Kober, E. M.; Sullivan, B. P.; Dressick, W. J.; Caspar, J. V.; Meyer, T. J. *J. Am. Chem. Soc.* **1980**, *102*, 7385. (b) Caspar, J. V.; Kober, E. M.; Sullivan, B. P.; Meyer, T. J. *J. Am. Chem. Soc.* **1982**, *104*, 630.

(4) (a) Caspar, J. V.; Meyer, T. J. *Inorg. Chem.* **1983**, *22*, 2444. (b) Caspar, J. V.; Meyer, T. J. *J. Phys. Chem.* **1983**, *87*, 952.

(5) (a) Kober, E. M.; Marshall, J. L.; Dressick, W. J.; Sullivan, B. P.; Caspar, J. V.; Meyer, T. J. *Inorg. Chem.* **1985**, *24*, 2755. (b) Kober, E. M.; Caspar, J. V.; Lumpkin, R. S.; Meyer, T. J. *J. Phys. Chem.* **1986**, *90*, 3723.

(6) (a) Barigelletti, F.; Juris, A.; Balzani, V.; Belser, P.; von Zelewsky, A. *J. Phys. Chem.* **1987**, *91*, 1095. (b) Juris, A.; Barigelletti, F.; Balzani, V.; Belser, P.; von Zelewsky, A. *Inorg. Chem.* **1985**, *24*, 202.

(7) (a) Allen, G. H.; White, R. P.; Rillema, D. P.; Meyer, T. J. *J. Am. Chem. Soc.* **1984**, *106*, 2613. (b) Henderson, L. H.; Fronczek, F.; Cherry, W. R. *J. Am. Chem. Soc.* **1984**, *106*, 5876. (c) Cherry, W. R.; Henderson, L. H. *Inorg. Chem.* **1984**, *23*, 983. (d) Pinnick, D. V.; Durham, B. *Inorg. Chem.* **1984**, *23*, 3841. (e) Caspar, J. V.; Westmoreland, T. D.; Allen, G. H.; Bradley, P. G.; Meyer, T. J.; Woodruff, W. H. *J. Am. Chem. Soc.* **1984**, *106*, 3492.